

17 COLUMN DETAIL
SCALE: 3/4"=1'-0"

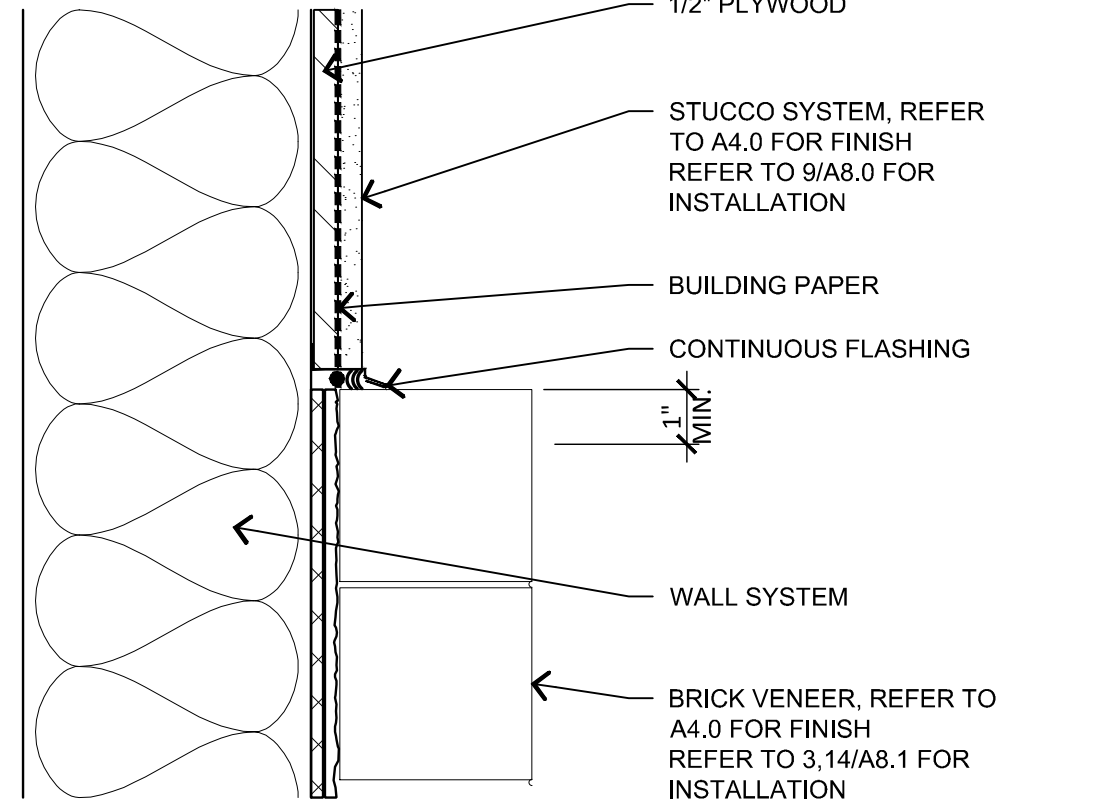

13 STUCCO TO BRICK CONNECTION
SCALE: 3"=1'-0"

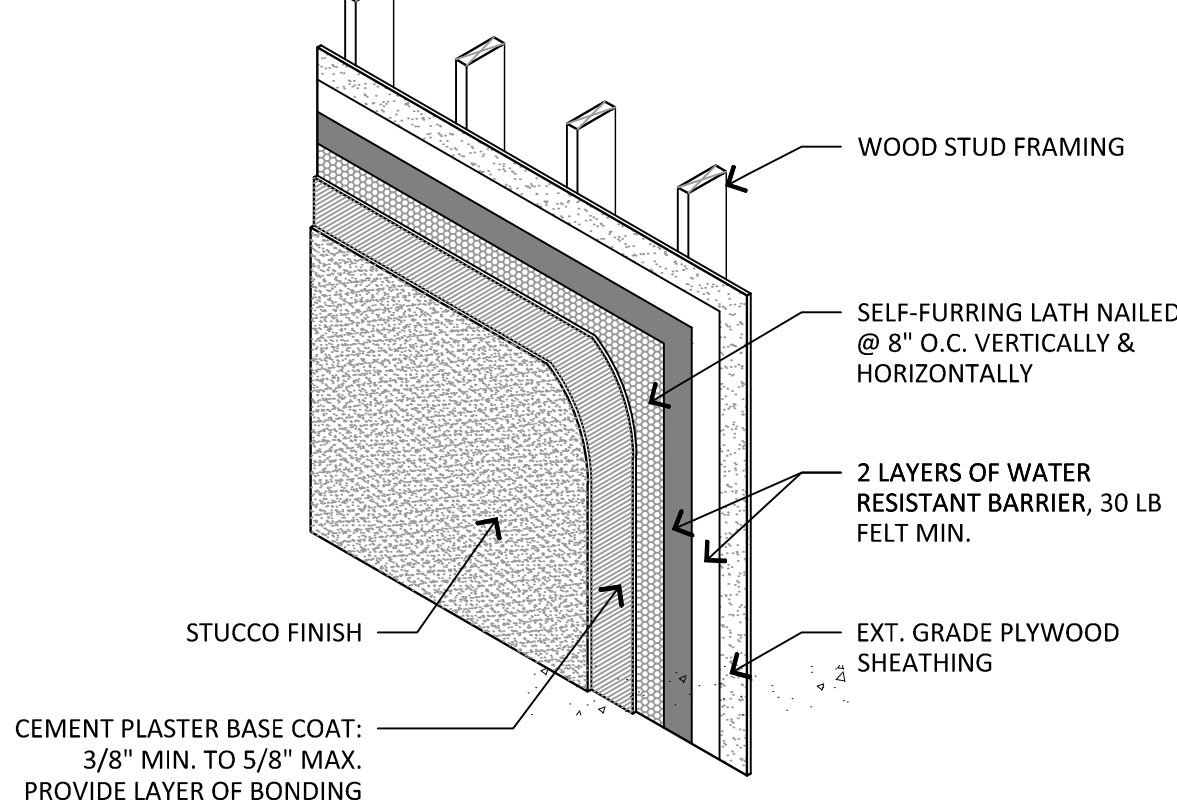

9 STUCCO SYSTEM ON WOOD STUDS
SCALE: 1/2"=1'-0"

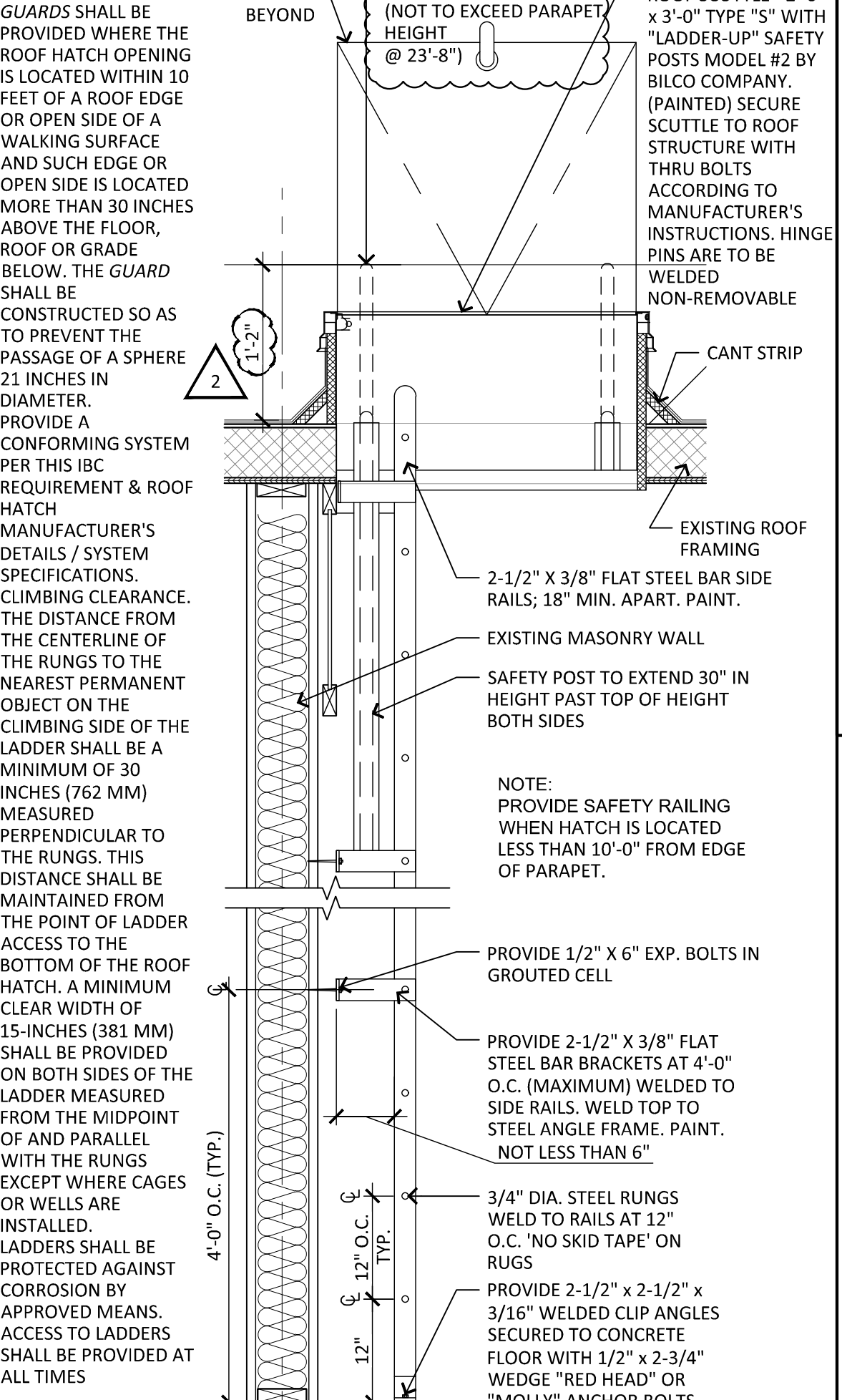

6 ROOF HATCH
SCALE: 1"=1'-0"

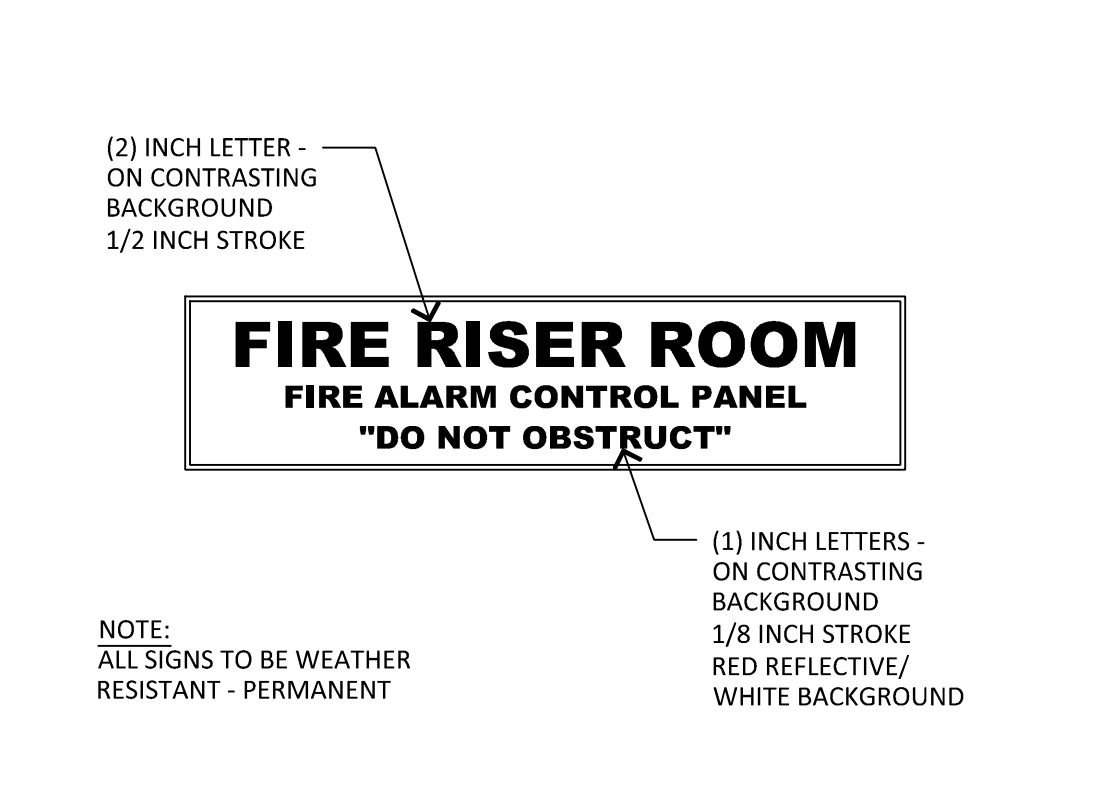

1 FIRE RISER DOOR SIGN
SCALE: 1-1/2"=1'-0"

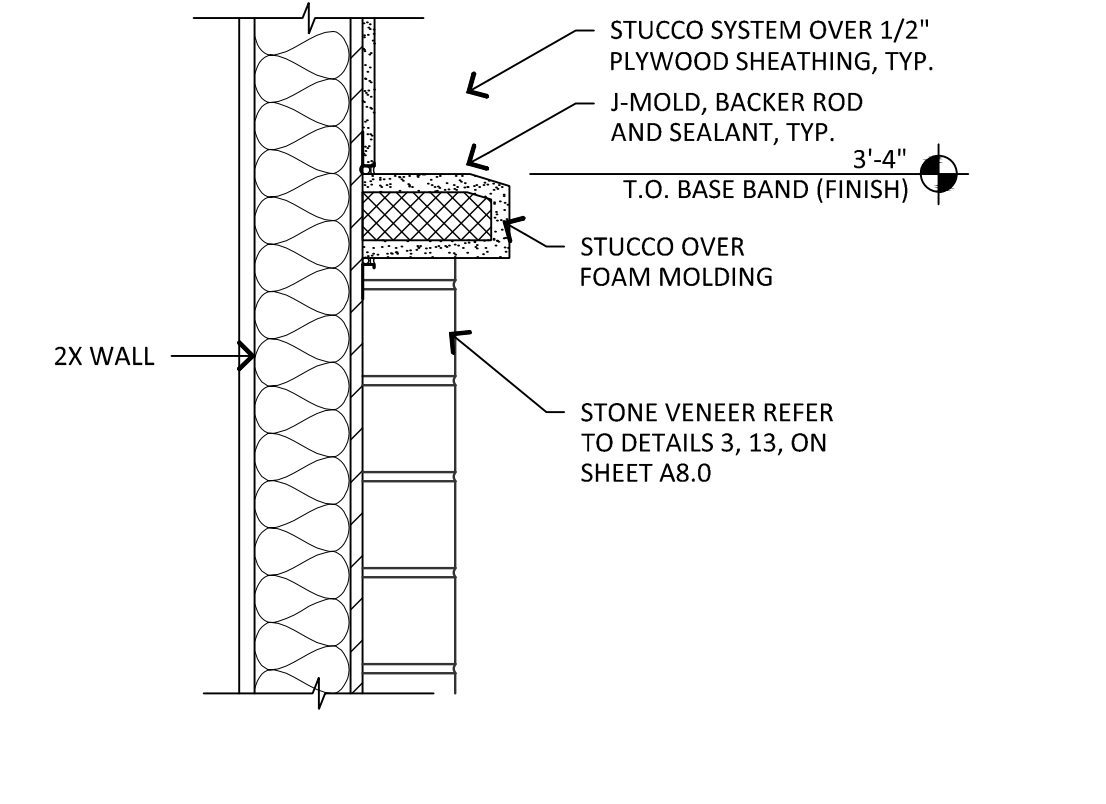

18 STUCCO POPOUT DETAIL
SCALE: 1-1/2"=1'-0"

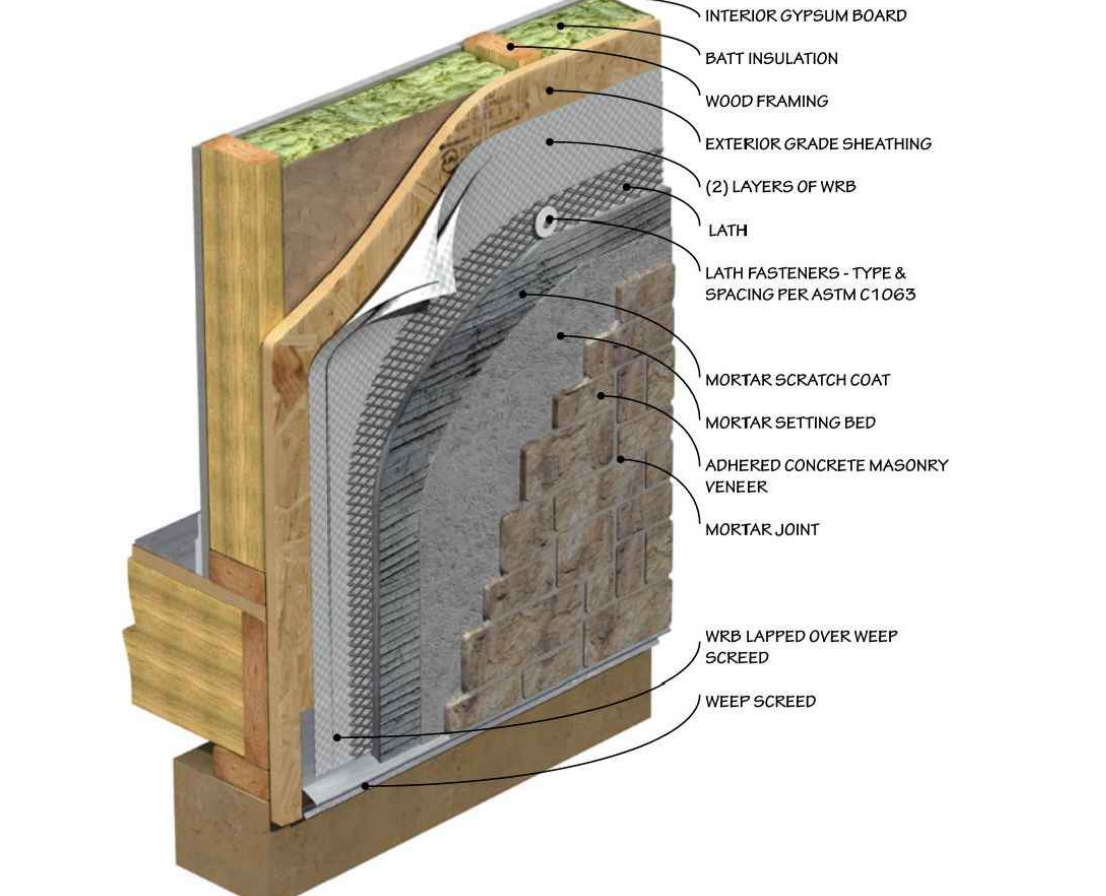

14 BRICK AT WOOD FRAME DETAIL
SCALE: 1-1/2"=1'-0"

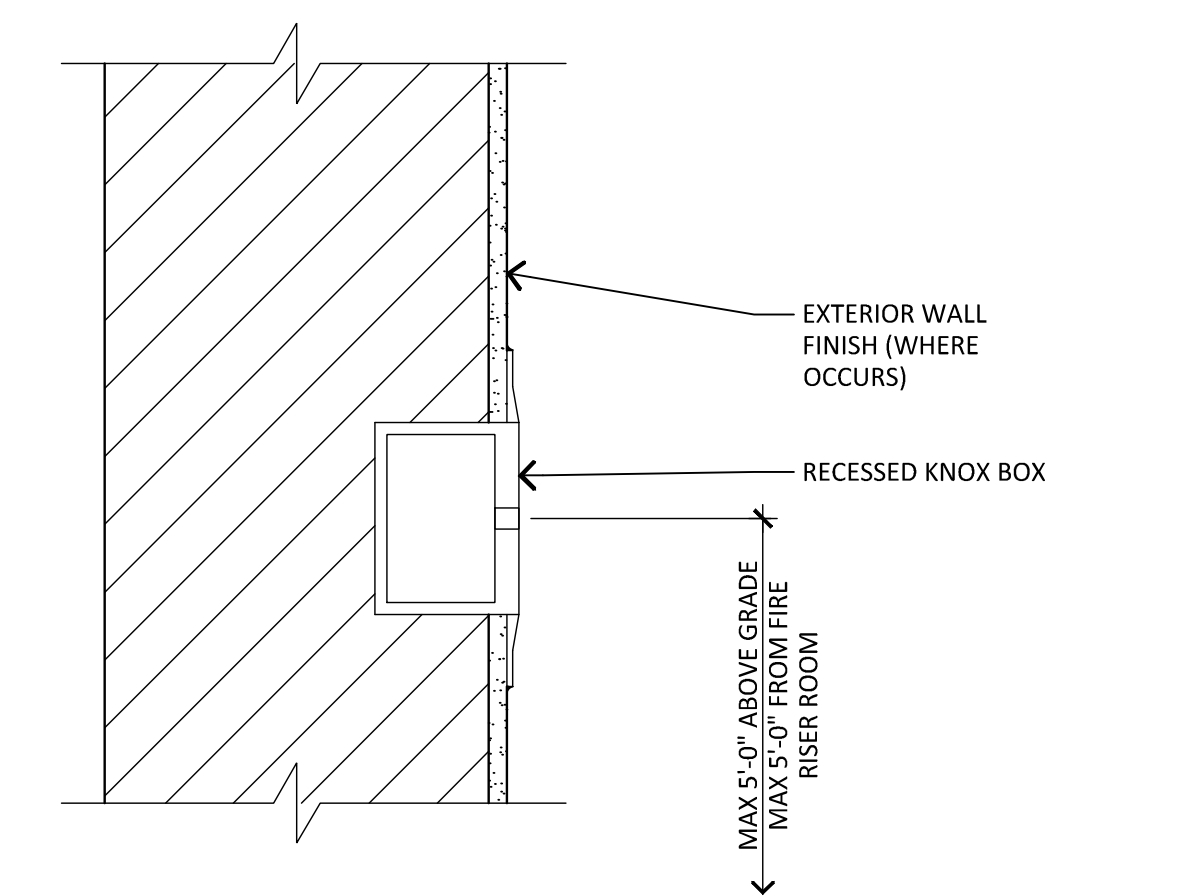

10 FIRE DEPARTMENT KNOW BOX
SCALE: 3"=1'-0"

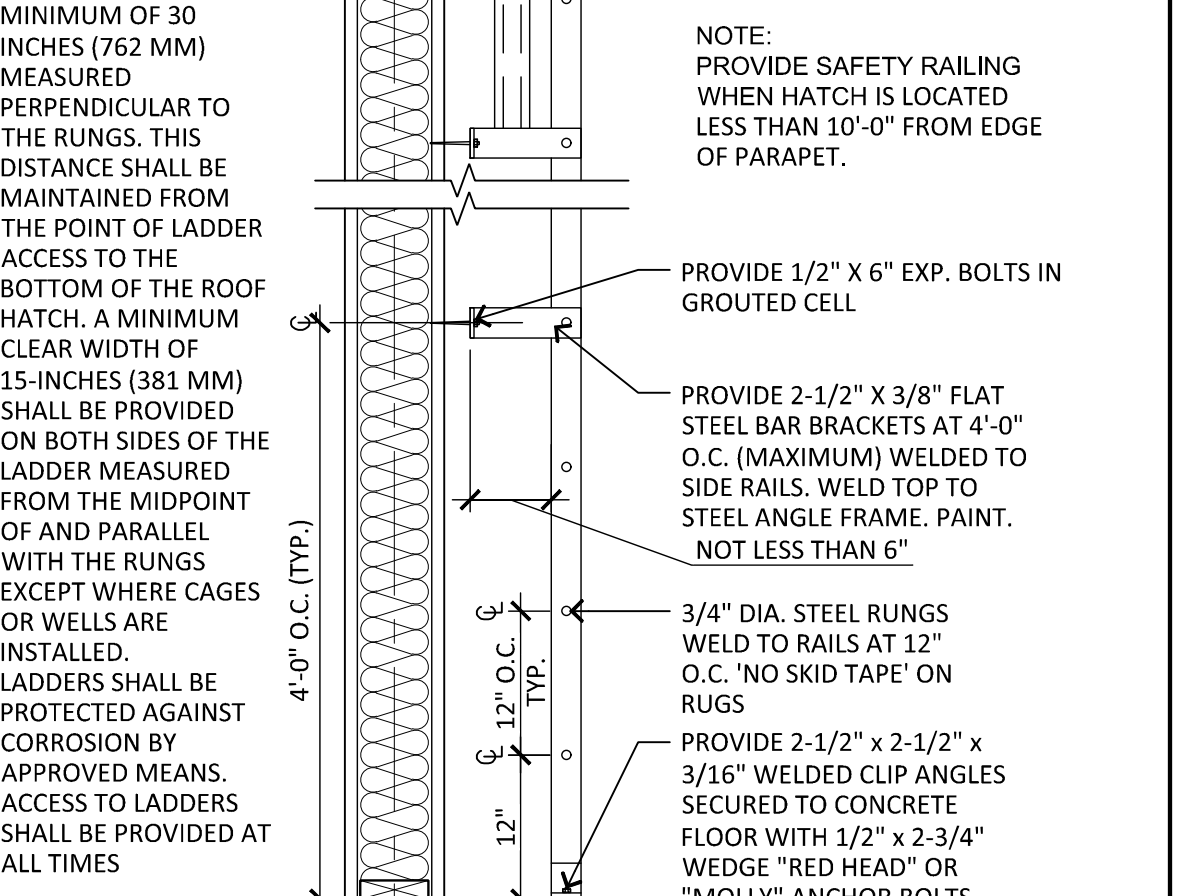

7 CANOPY AT WALL
SCALE: 1"=1'-0"



3 BRICK AT WOOD FRAME DETAIL
SCALE: 3"=1'-0"



15 COLUMN DETAIL
SCALE: 3/4"=1'-0"

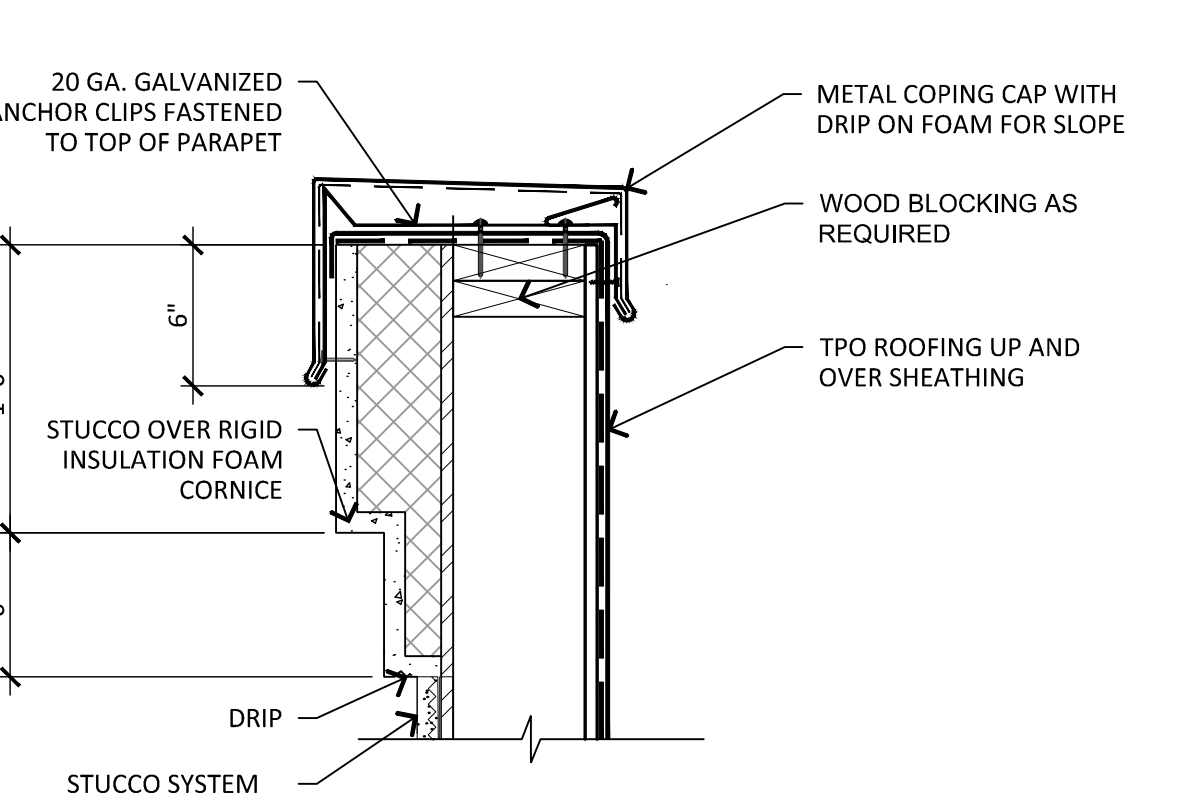

11 PARAPET DETAIL
SCALE: 1-1/2"=1'-0"

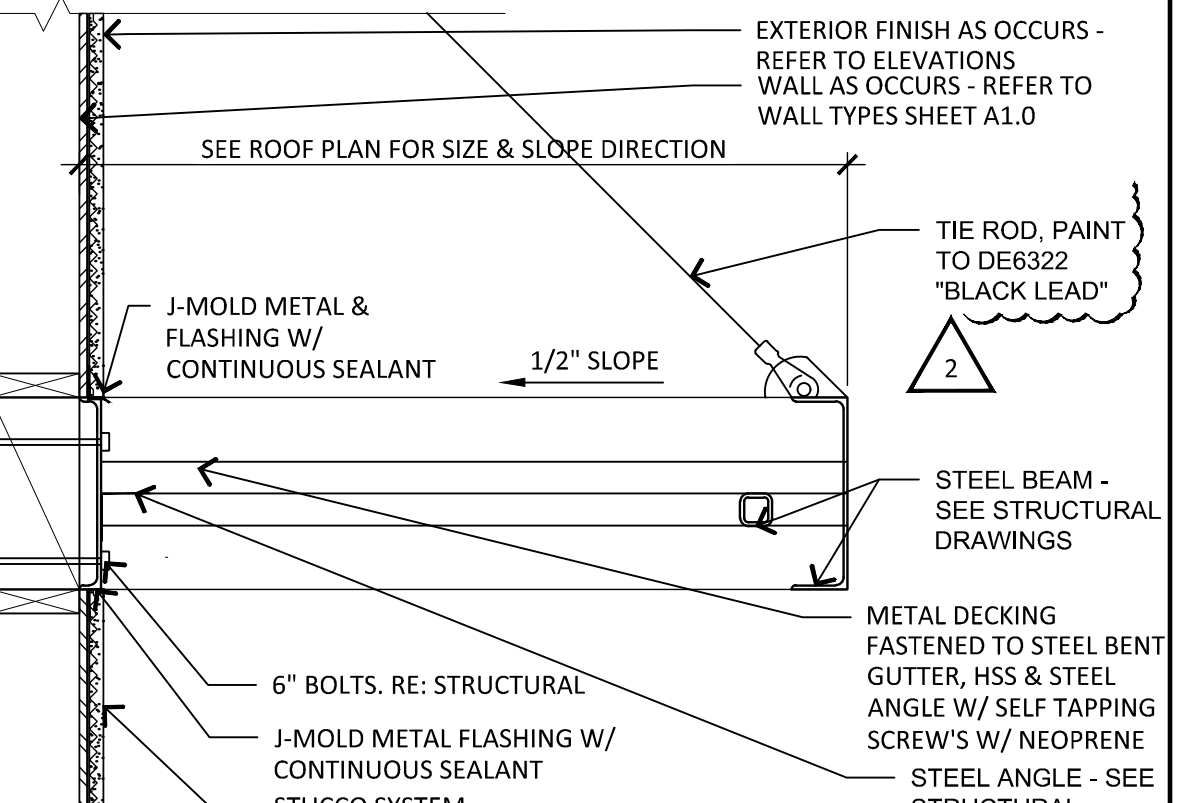

8 CANOPY AT STOREFRONT
SCALE: 1"=1'-0"

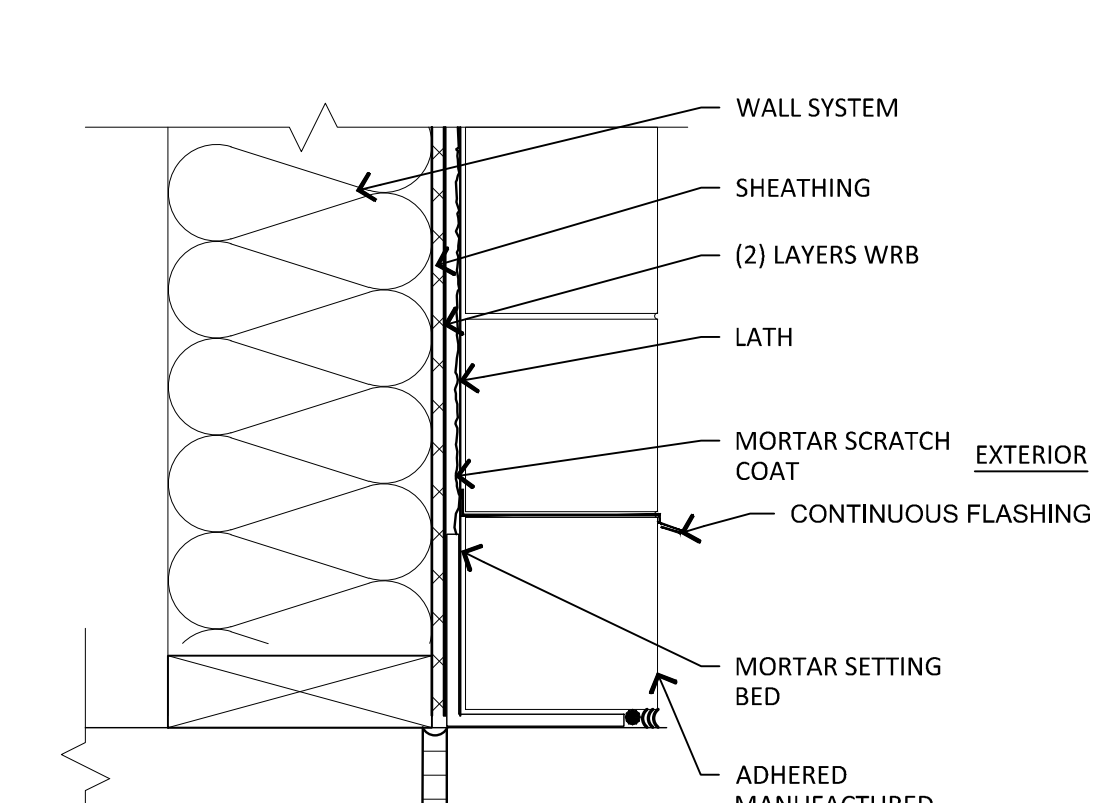

4 ROOF DRAIN AND OVERFLOW
SCALE: 1"=1'-0"



16 SOFFIT EDGE AND VENT DETAIL
SCALE: 3/4"=1'-0"

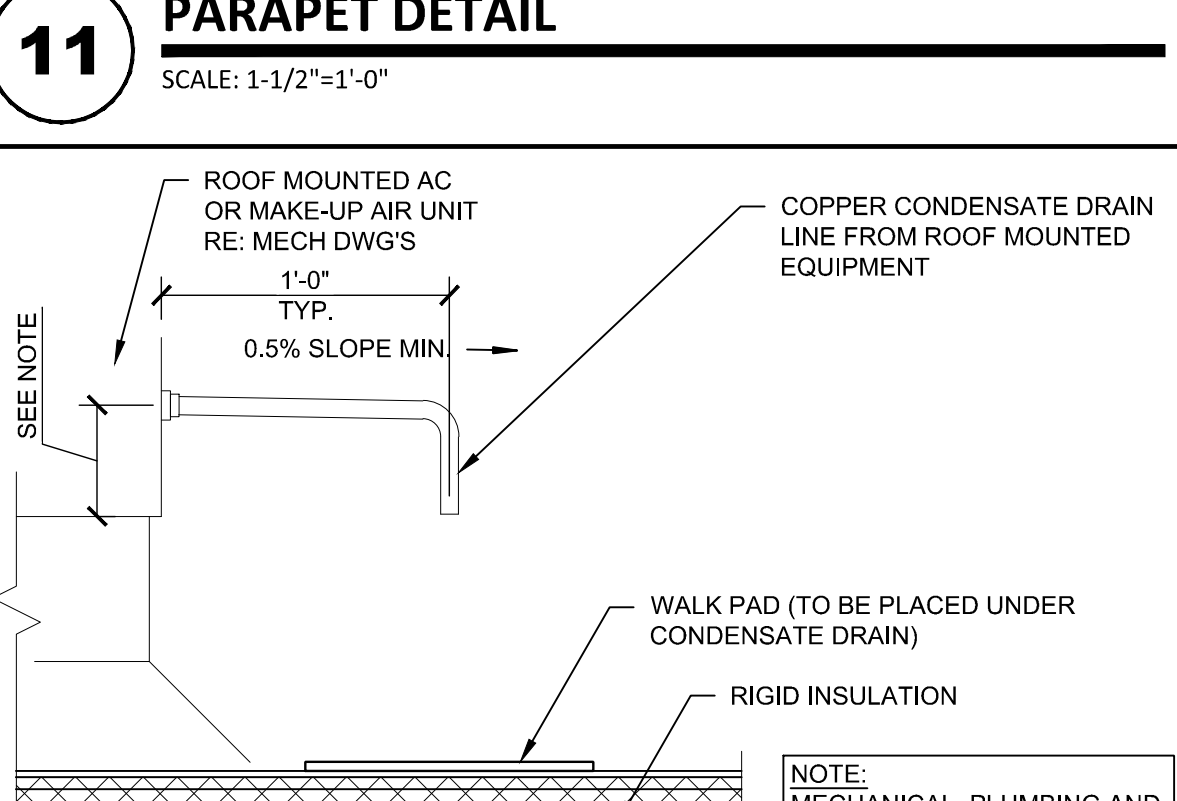

12 ROOFTOP CONDENSATE DRAIN
SCALE: 1-1/2"=1'-0"

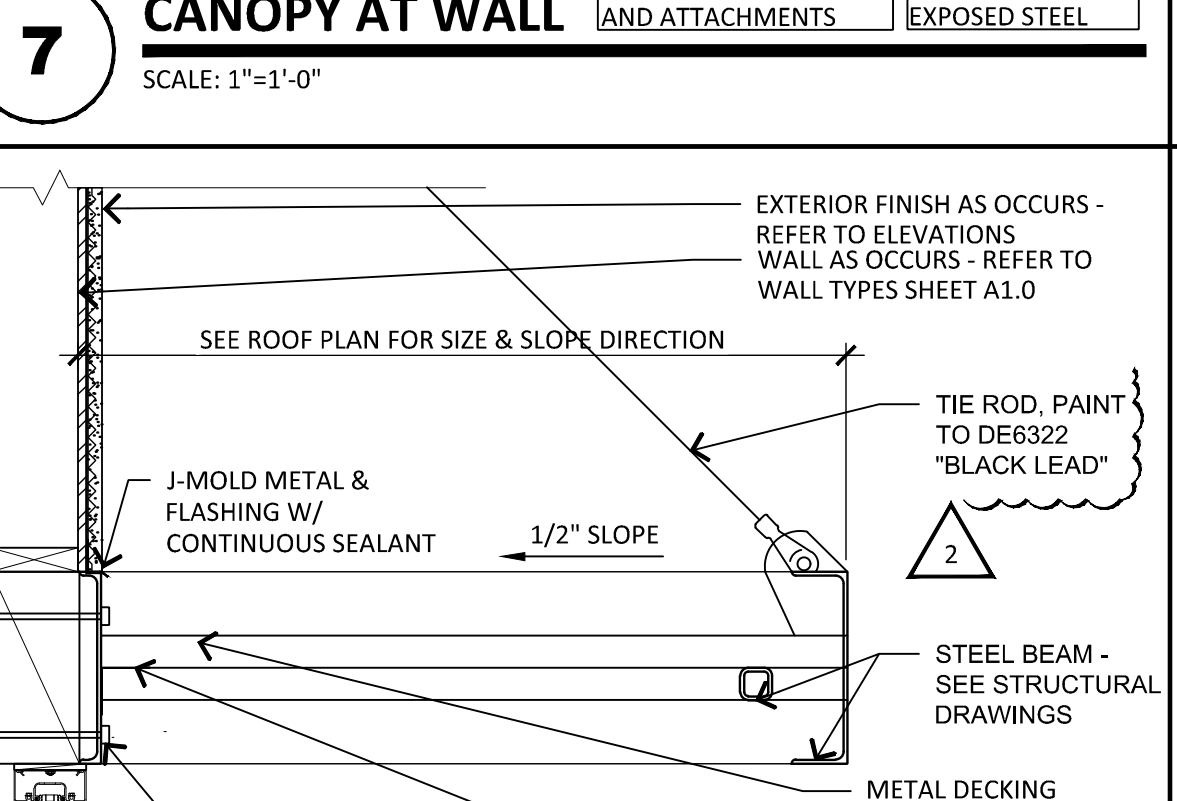

7 CANOPY AT WALL
SCALE: 1"=1'-0"

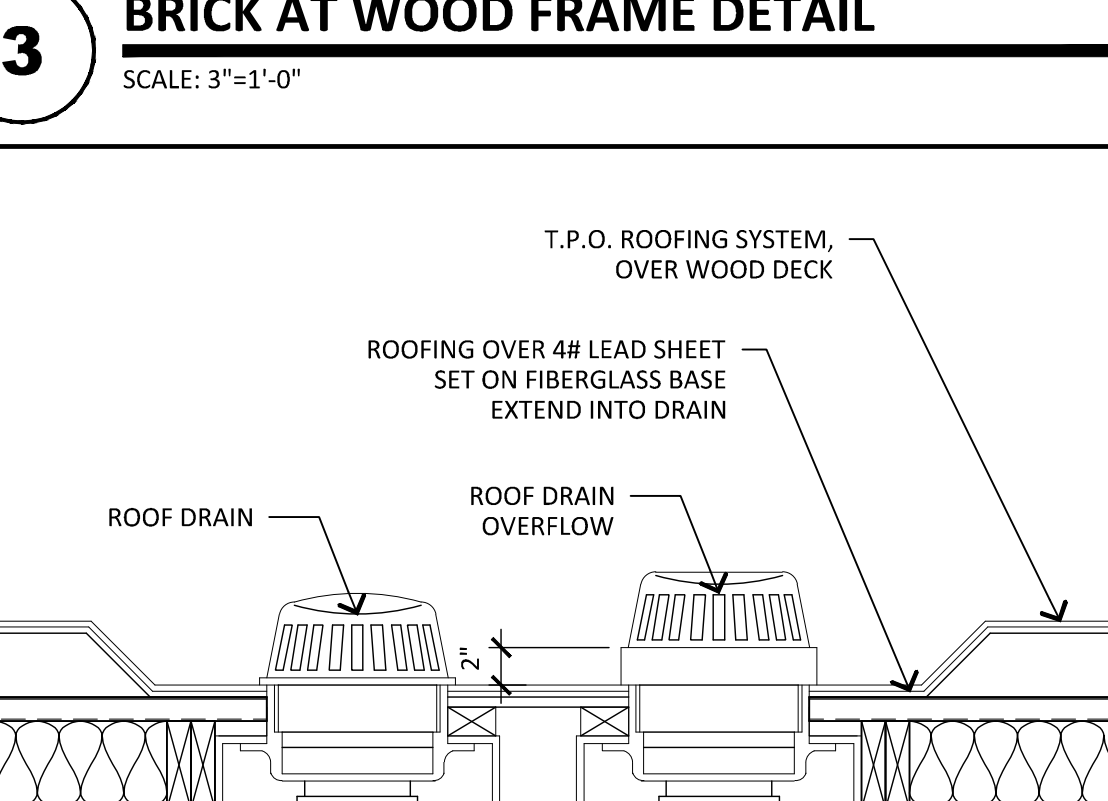

3 BRICK AT WOOD FRAME DETAIL
SCALE: 3"=1'-0"



IRKKA
ARCHITECTS
2333 EAST THOMAS ROAD, PHOENIX, ARIZONA 85016
602-955-3900

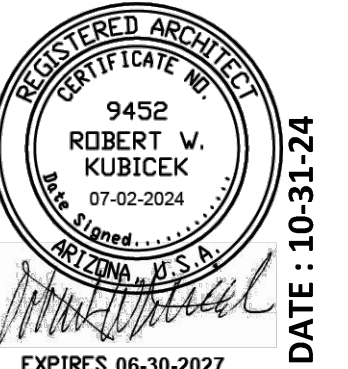

OWNER CHANGES
CITY COMMENTS
ADDITIONS
DATE: 10-31-24
EXPIRES: 06-30-2027

NOTICE OF ALTERNATE BILLING OR PAYMENT CYCLE: THIS CONTRACT MAY ALLOW THE OWNER TO REQUIRE THE SUBMISSION OF BILLING OR ESTIMATES IN BILLING CYCLES OTHER THAN THIRTY DAYS. THIS CONTRACT MAY ALLOW THE OWNER TO MAKE PAYMENT CERTIFICATION AND APPROVAL OF BILLING AND ESTIMATES. A WRITTEN DESCRIPTION OF SUCH OTHER BILLING CYCLE APPLICABLE TO THE PROJECT IS AVAILABLE FROM OWNER OR DESIGNATED AGENT.
NEW COMMERCIAL PAD
PAD 58 AT PASEO UNDO SHOPPING CENTER
NEC OF ARIZONA AVE AND OCCOTILLO RD.
CHANDLER, AZ
CONSTRUCTION SET_11-12-24
DETAILS

design by: RH
drawn by: RL
checked by: RH

A8.0
project #: 23057